

Hole in plate

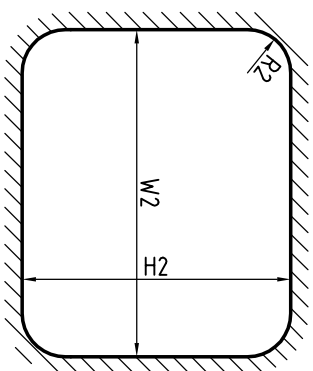

Materials:
 Welding frame: Mild steel/Aluminum/Stainless steel
 Glass/frame: Brass/Aluminum
 Screwin/list: Brass/Aluminum/Stainless steel
 Hinge pins: Brass/Stainless steel
 U-Sealant: Rubber
 Glasspane: Toughened glass,
 tested acc. to ISO 614
 Screws: Brass/Stainless steel DIN 966, M6×16/M6×20
 Fasteners: Brass/Stainless steel
 Sliding expander: Brass/Stainless steel

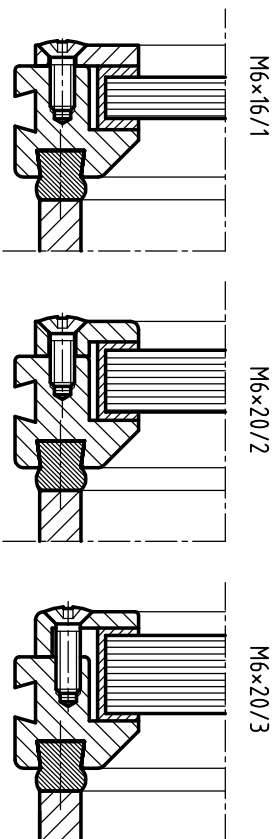
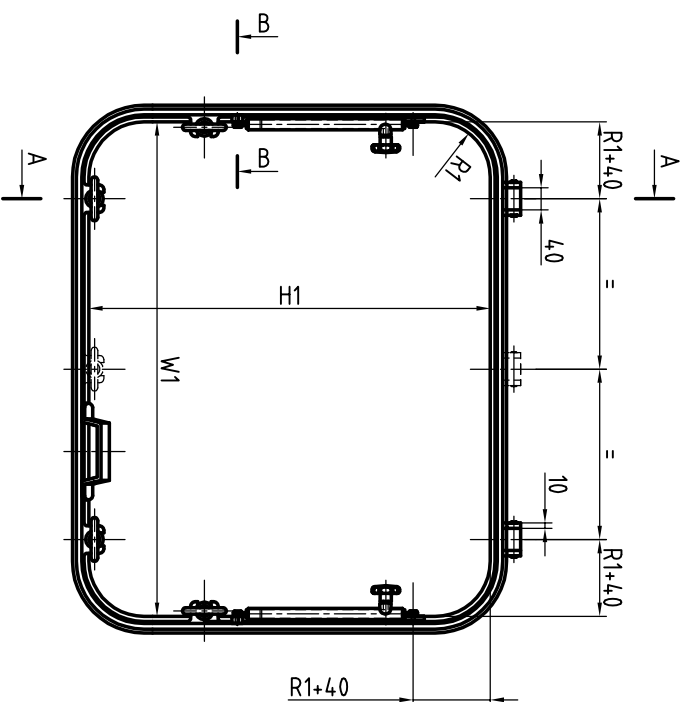
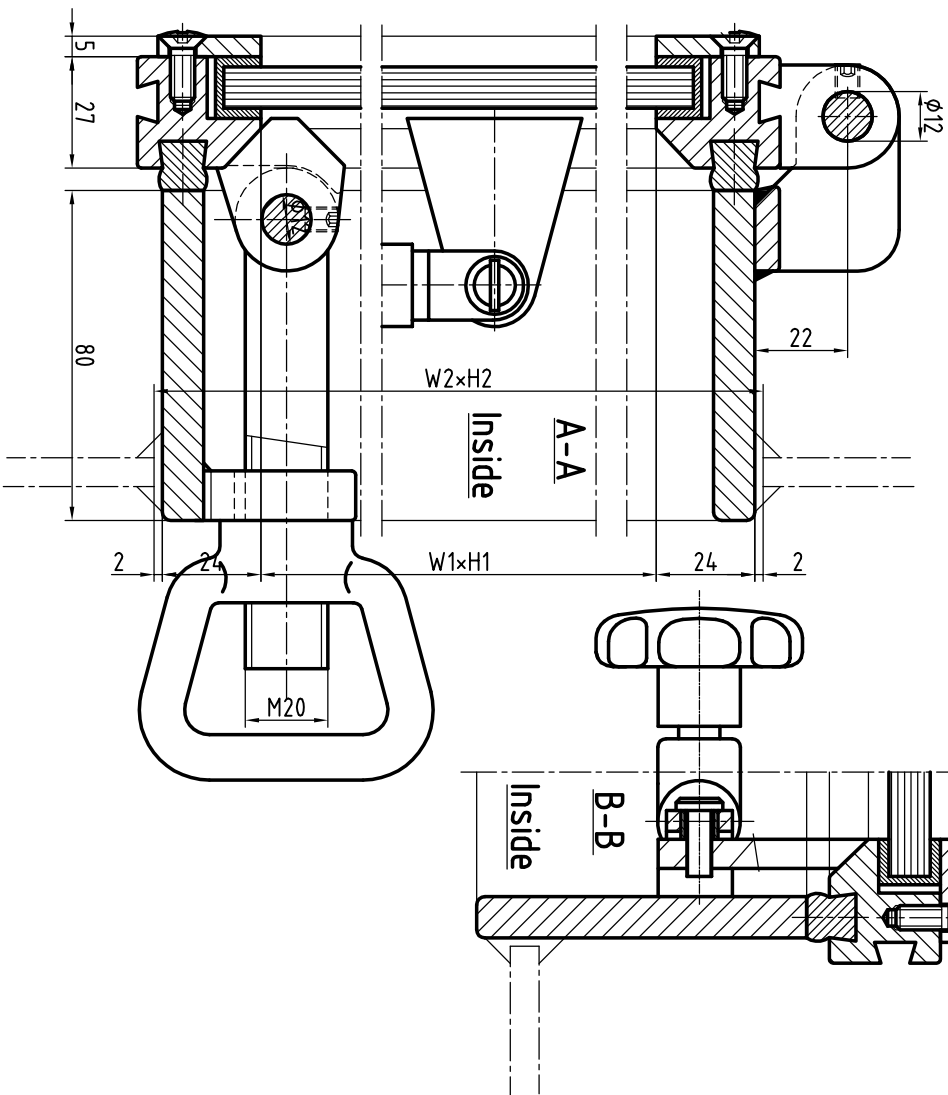

* with 8 fasteners

No	Nominal size	Hole in plate	Radius	Glass thick.	Screws and list	Frame
1	500×710	552×762	R1 R2	15	type E type F	height
2	560×800	612×852	100	126	M6×20/2 M6×16/1	standard-80mm
3	900×630	952×682	100	126	M6×20/2 M6×16/1	
4*	1000×710	1052×762	100	126	M6×20/3 M6×16/1	
5*	1100×800	1152×852	100	126	M6×20/2	

PROMAP LTD.
Bydgoszcz, POLAND

Drawn: Skenski Date: 01-04-2014
 Title: **Outside hinged window OTW**
 Tel: +48 52 3216131 Fax: +48 52 3764726
 Email: promap@promap.eu

ISO 3903
 AutoCAD file no. **WHW-05**