

Hole in plate

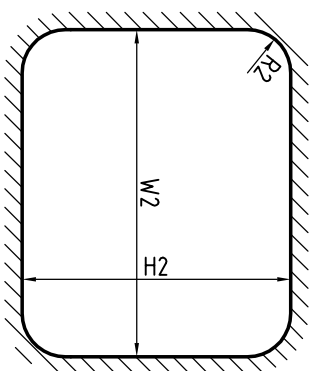

Materials:
 Welding frame: Mild steel/Aluminum/Stainless steel
 Glass frame: Stainless steel
 Screw/Inlist: Aluminum/Stainless steel
 Hinge pins: Stainless steel
 U-Sealant: Rubber
 Glasspane: Toughened glass,
 tested acc. to ISO 614
 Screws: Stainless steel DIN 966, M6x16/M6x20
 Fasteners: Stainless steel
 Sliding expander: Stainless steel

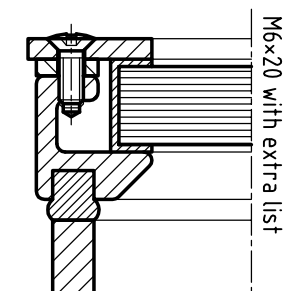
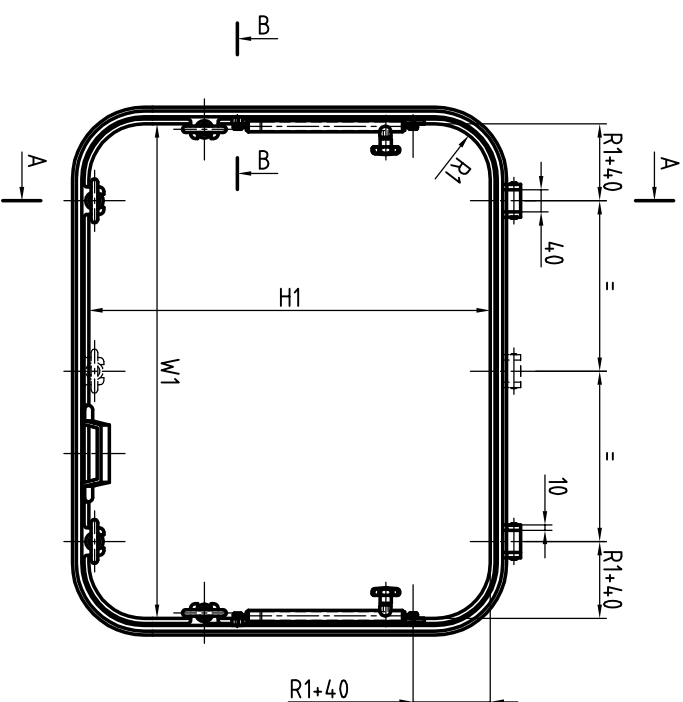
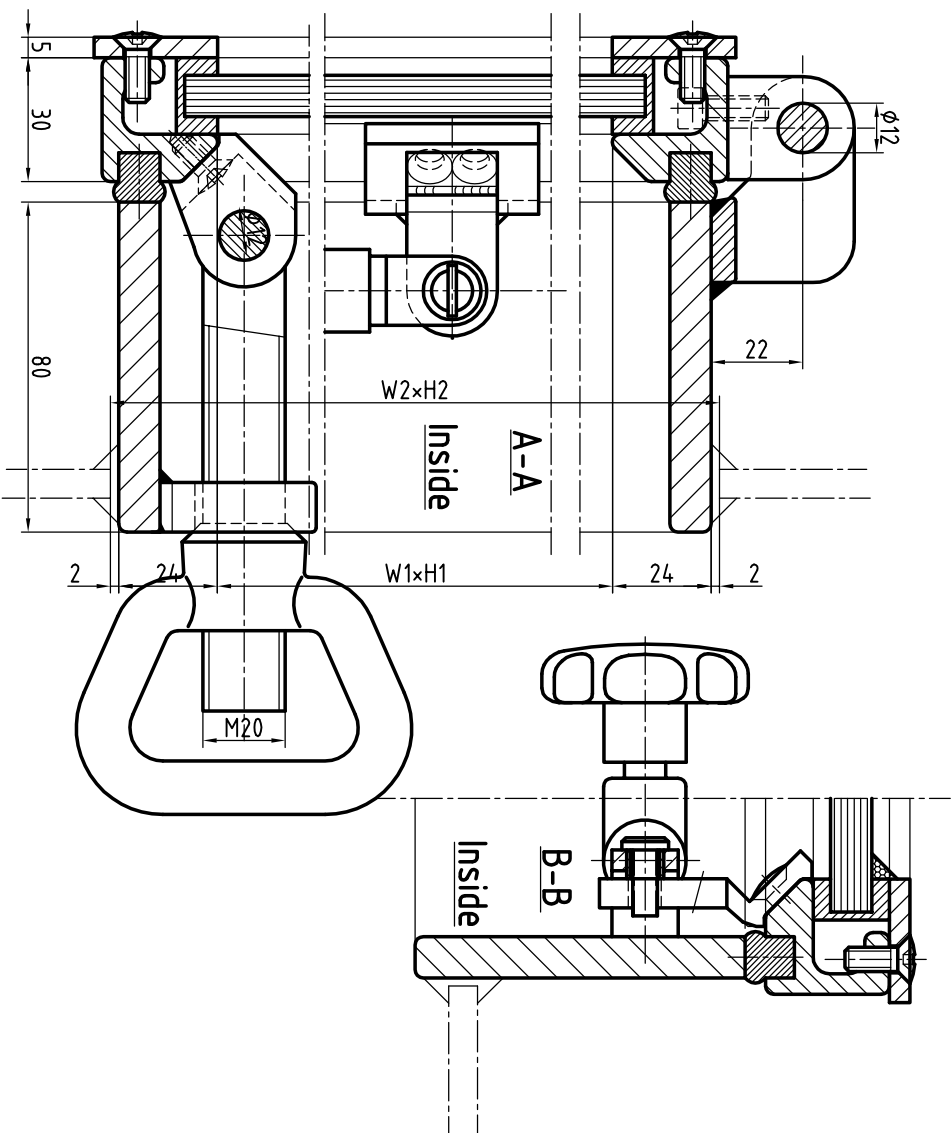

* with 8 fasteners

No	Nominal size	Hole in plate	Radius	Glass thick.	Screws and list	Frame height
1	500x710	552x762	R1 R2	type E type F	type E type F	standard-80mm
2	560x800	612x852	100	15	10	M6x16
3	900x630	952x682	100	126	15	10
4*	1000x710	1052x762	100	126	19	12
5*	1100x800	1152x852	100	126	-	15

PROMAP LTD.
 Bydgoszcz, POLAND

Drawn: Skenski Date: 01-04-2014

Title: **Outside hinged window OTW**

Tel: +48 52 3216131 Fax: +48 52 3764726

Email: promap@promap.eu

ISO 3903

AutoCAD file no. **WHW-05.1**