

Hole in plate

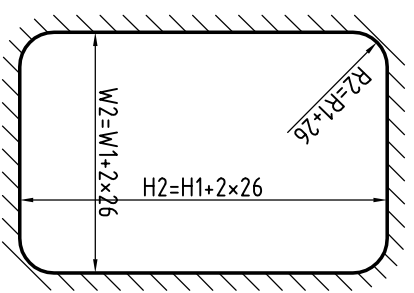

- Materials:
 Welding frame: Mild steel/Aluminum/Stainless steel
 Glass frame: Brass/Aluminum
 Screwing list: Brass/Aluminum/Stainless steel
 Hinge pins: Brass/Stainless steel
 U-Sealant: Rubber
 Glasspane: Toughened glass,
 tested acc. to ISO 614
 Screws: Brass/Stainless steel DIN 966, M6x16/M6x20
 Fasteners: Brass/Stainless steel
 Sliding expander: Brass/Stainless steel

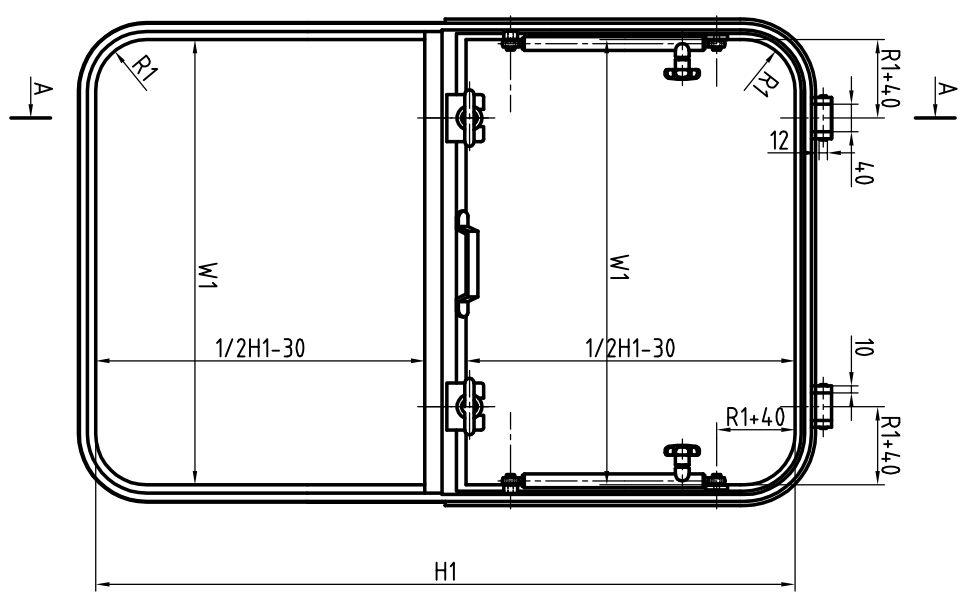

Frame height - standard H=80

PROMAP LTD.		Drawn:	Date:
Bydgoszcz, POLAND		Skenski	28-04-2014
Fixed two parts window		with hinged part	
Title		Tel: +48 52 3216131	Fax: +48 52 3764726
Email: promap@promap.eu		AutoCAD file no.	
WHW-01		WHW-01	